



## CLUBCAR PD-PLUS INSTALLATION GUIDE

The following steps describe the installation of the Alltrax, Inc. DCX controller in a Club Car PD Plus series golf car. Refer to the Club Car PD Plus schematic (**Doc100-065 available online**) during installation.

NOTE: *This adapter does **not** work on Regen 1 Cars*



**CAUTION:** This installation must be performed by a qualified or trained golf car technician. Use caution when working on battery power vehicles and observe all safety precautions. Elevate drive wheels prior to testing any electric vehicle.

### Procedures:

1. Cut white wire in wiring harness leaving enough on both ends to connect with butt connector.
2. Splice the 5 ½" white wire from the kit onto the two ends of the white wire that was cut.
3. Connect opposite end of 5 ½" wire to J3 on the adaptor.
4. Cut Solid BLUE wire coming from solenoid close to the wiring harness.
5. Splice together the blue wire from the solenoid, the 12" and 33" blue wire from the adaptor kit using the butt connector.
6. Feed the other end of the 33" wire under the passenger compartment.
7. Plug the other end of the 12" wire onto J2 of the adaptor.
8. Cut the blue wire between the two wire bundles and splice the two ends onto the 33" wire from the motor compartment. **If only one wire bundle, connect blue wire to BLUE wire from key switch.**
9. Attach motor's A1 terminal (green wire) to controller's M- bus bar.
10. Attach motor's A2 terminal (white wire) to controller's B+ bus bar along with the YELLOW cable from the Solenoid. On "Power-Drive Plus" model cars the regen solenoid should be removed. It's not used with Alltrax controllers. Also tape up two wires that control the solenoid.
11. Install new Diode (1N4001) as listed in **Doc100-065** across contactor control with white stripe toward the positive side.
12. Install pre-charge resistor, as listed in (**Doc100-065**), across main contactor of solenoid.
13. Connect controller's F1 lug to motor's F1 terminal with orange cabled supplied in kit.
14. Connect controller's F2 lug to motor's F2 terminal using BLUE wire from kit.
15. Plug black control plug into the controller adaptor.
16. Double check all the wiring. (**Doc100-065**)
17. Set the Tow/Run switch in the "Run" position.
18. Verify the forward and reverse **slowly while still on jacks** to verify controller operation and field windings are correct. (**If car runs backwards when in Fwd, reverse F1 and F2 wires at controller**)

The Club Car PD-Plus circuit board adapter plugs onto the front the DCX 10-pin connector using one of the mounting screws (supplied). Use care not to over tighten the PCB #6 screw.



**The circuit board is covered with a sticky substance – DO NOT REMOVE this material. It is an environmental coating to help reduce corrosion.**

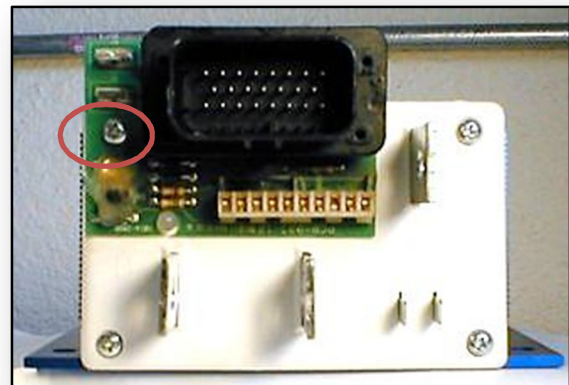

See the Adapter pin-out and installation photos shown in the next few pages.

**Installation Pictures:**

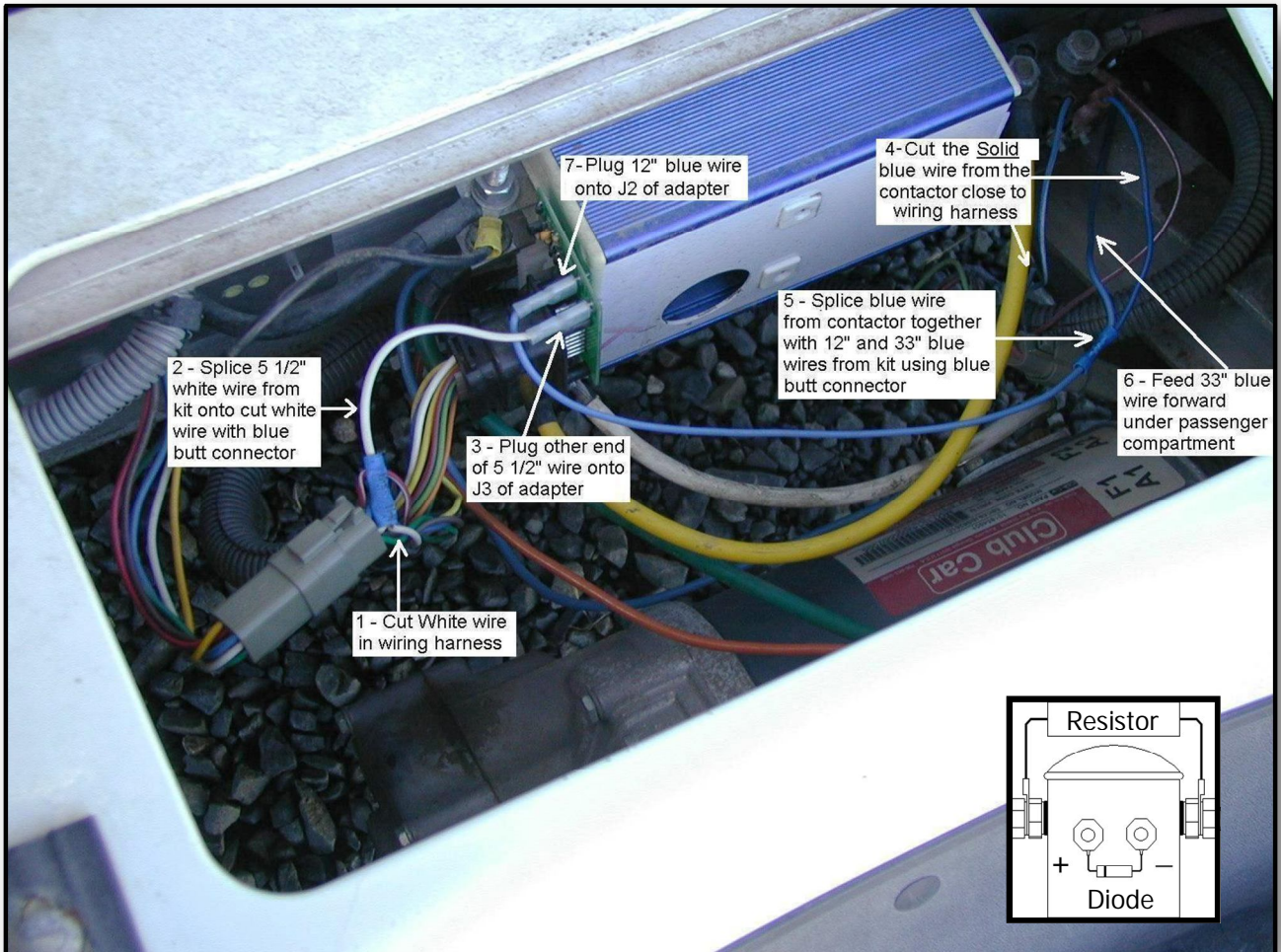

**Installation Pictures:**

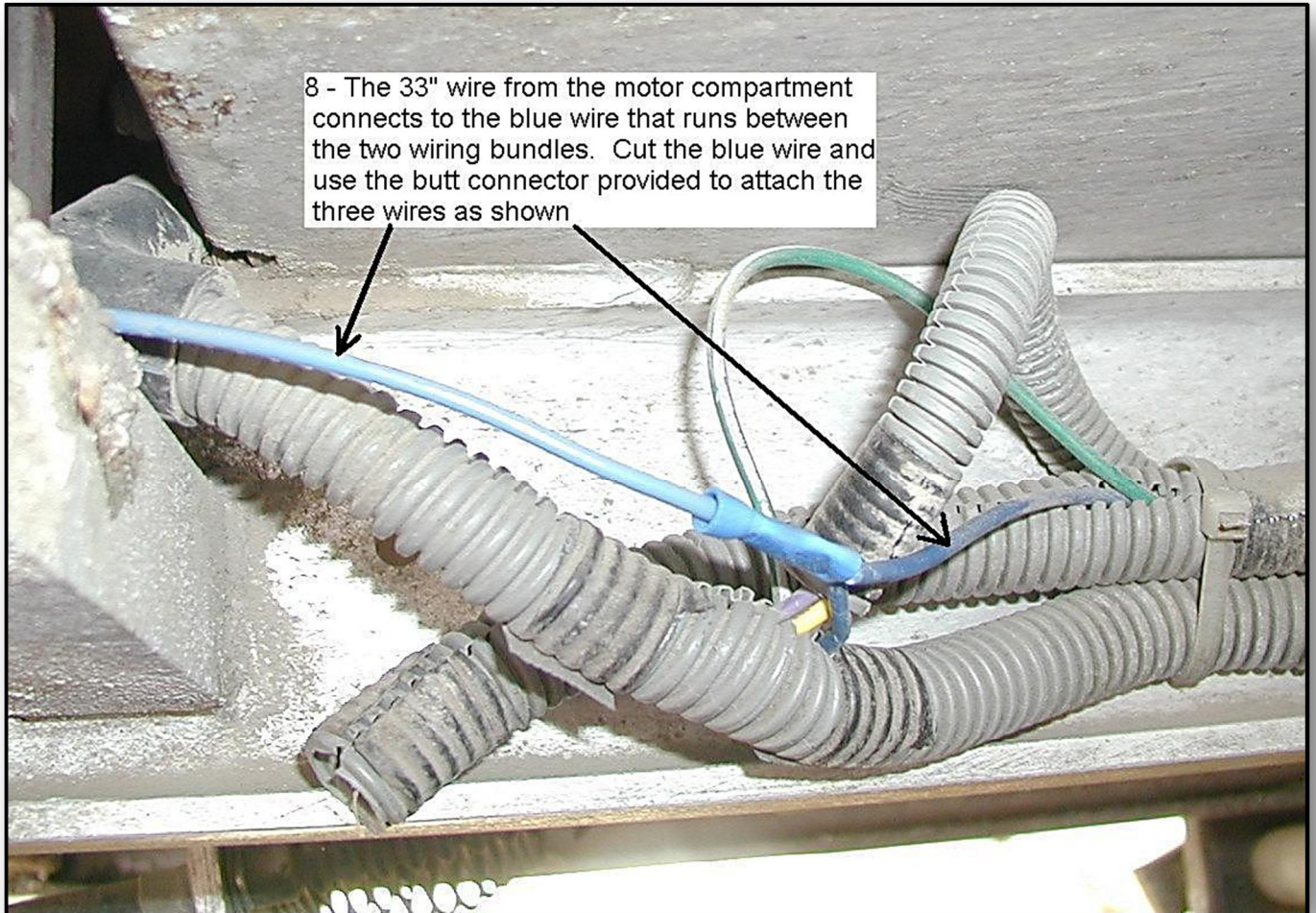

**Adapter Pin out Diagram:**

**NOTE: This adapter does not work on Regen 1 Cars**

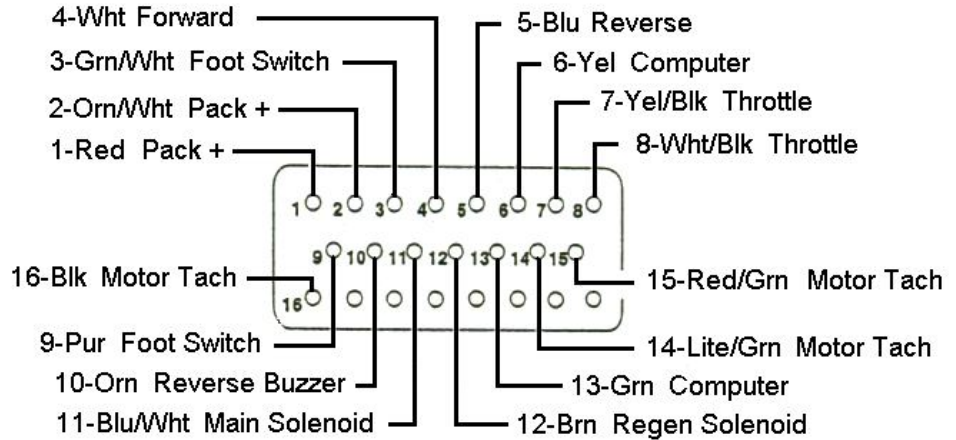

**NOTE: If you get a HPD (High Pedal Disable) error on the controller (three red blinks), verify the Throttle Micro Switch is being activated BEFORE the throttle signal changes.**

**PD Plus Adapter Schematic**

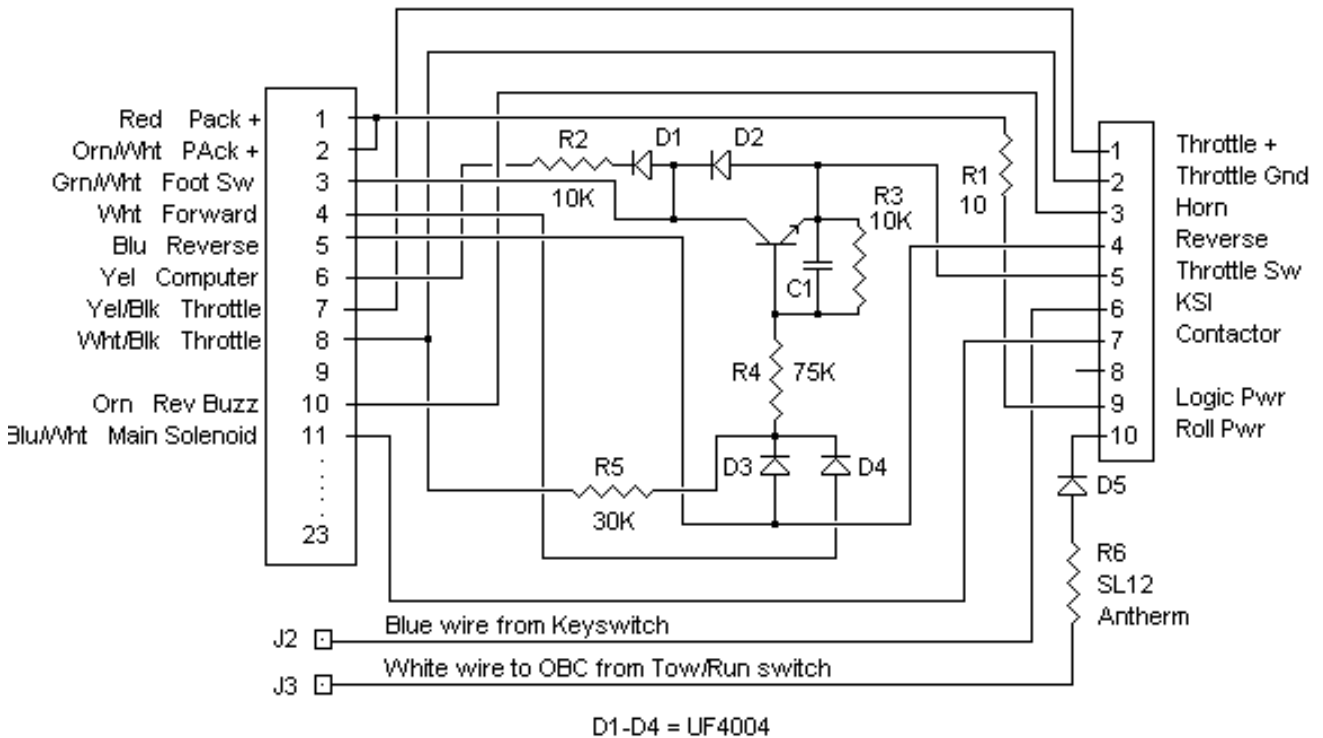

Kit wires and adapter:

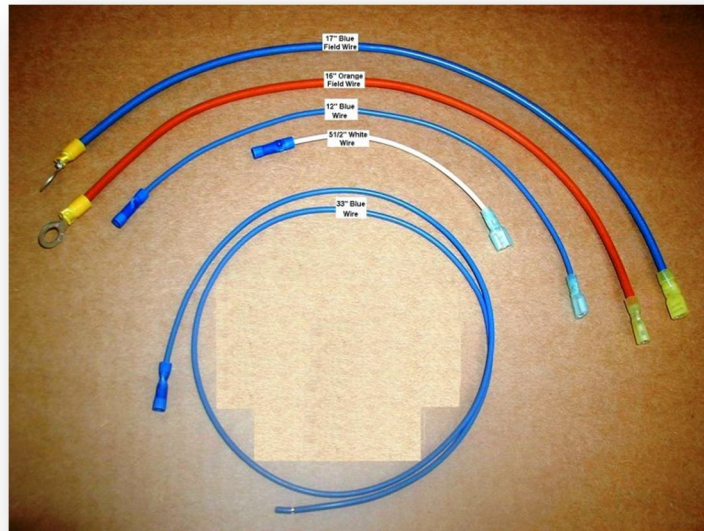
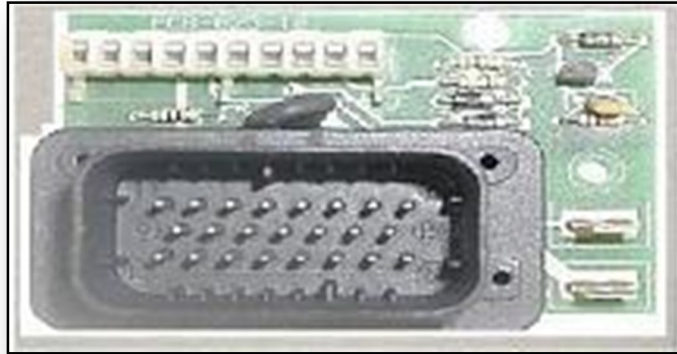

Alltrax reserves the right to change documentation without notice.

Alltrax makes no warranty as to the accuracy, sufficiency, or suitability of any technical or other information provided.

**For Technical Assistance, please call 541-476-3565**

ALLTRAX, Inc., 1111 Cheney Creek Rd. Grants Pass, OR 97527 541-476-3565

*Revision C: EC-090407 Made pictures larger, added clarification to reduce confusion.*

**ALLTRAX Inc., Company History:**

The company founder developed our core technology at the race track for high power electric vehicles. Throughout the 90's, the market demanded robust and high performance electronic controllers. In 2001 ALLTRAX was formed based on the E-race car developed technology.

Today, Power Conversion Engineering (PCE) is the research and development arm of ALLTRAX and provides the industry a powerful and robust controller to meet all your recreational, industrial, and commercial electrical vehicle needs.

For more information please go to <http://www.alltraxinc.com>  
Follow us on Facebook <http://www.facebook.com/AlltraxInc>



*"The company was founded at the track"*